



GBC37-900 HP: 450-900 Disp: 2.0L - 5.5L

Garrett Boost | Club Line turbochargers are high performance journal bearing products in a cost effective price range. GBC combines modern, high flowing aerodynamics with a robust journal bearing rotating group to make a powerful and affordable turbocharger.

Garrett
ADVANCING MOTION

Performance results of this product are highly dependent upon your vehicle's modifications and tuning/calibration. The target power represented above has been calculated based strictly on choke flow of the compressor map (total turbo capability), which represents the potential flywheel power.

GBC37-900 HP: 450-900 Disp: 2.0L - 5.5L



Features:

- Billet compressor wheel with extended tip design for higher pressure ratios
- 67mm compressor wheel with GTX Gen II compressor aerodynamics
- Journal bearing rotating group with 360-degree thrust bearing
- Outline interchangeable with GBC35-700 for stage upgrades
- Machined boost signal port with installed plug
- Modern turbine wheel aerodynamics
- Oil-cooled center housing

GBC37-900		Compressor				Turbine		
		Inducer	Exducer	Trim	A/R	Inducer	Exducer	Trim
HP: 450-900 Disp: 2.0L-5.5L		67mm	84mm	64	0.72	73	65	80
Supercore		PN						
		913840-5002S						
Turbine Kits: GBC37		PN		A/R	Inlet	Outlet	Wastegate	Divided
Interchangeable with GBC37		740902-0126		0.82	T3	V-Band	Free Float	N
Supercores		740902-0127		0.82	T4	V-Band	Free Float	N
		740902-0128		0.95	T4	V-Band	Free Float	Y

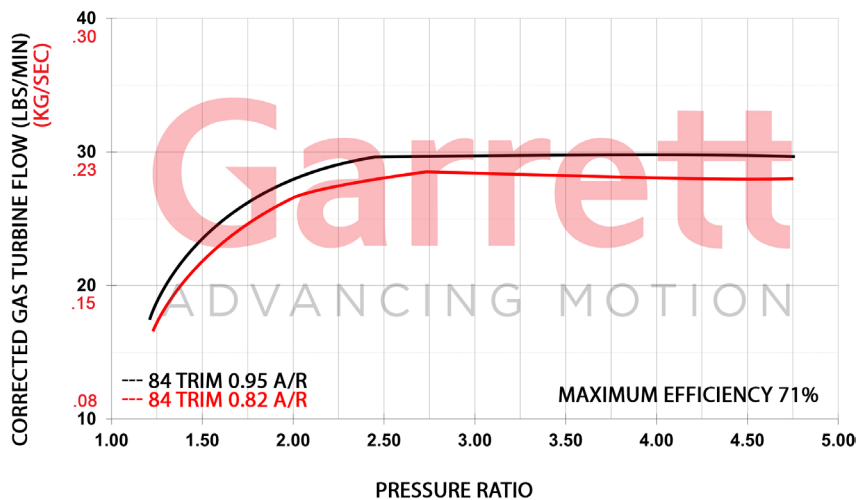
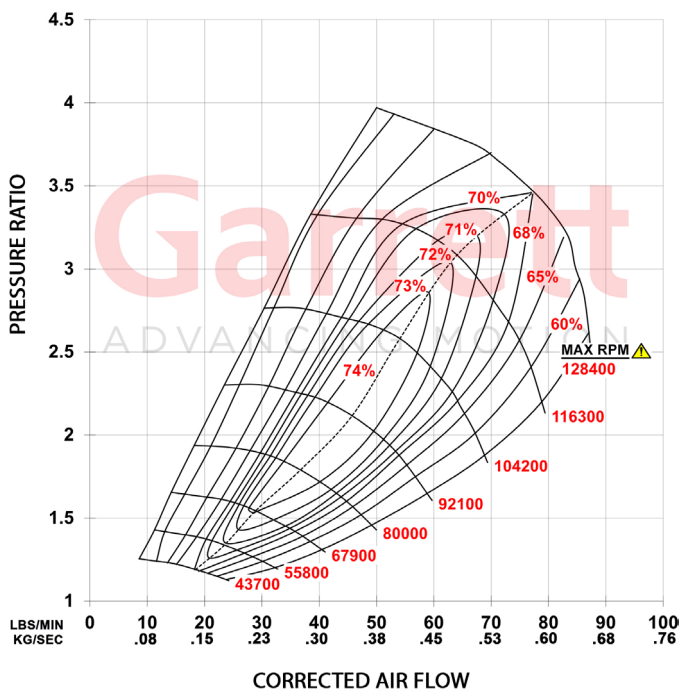

Performance results of this product are highly dependent upon your vehicle's modifications and tuning/calibration. The target power represented above has been calculated based strictly on choke flow of the compressor map (total turbo capability), which represents the potential flywheel power.

GBC37-900 HP: 450-900 Disp: 2.0L - 5.5L

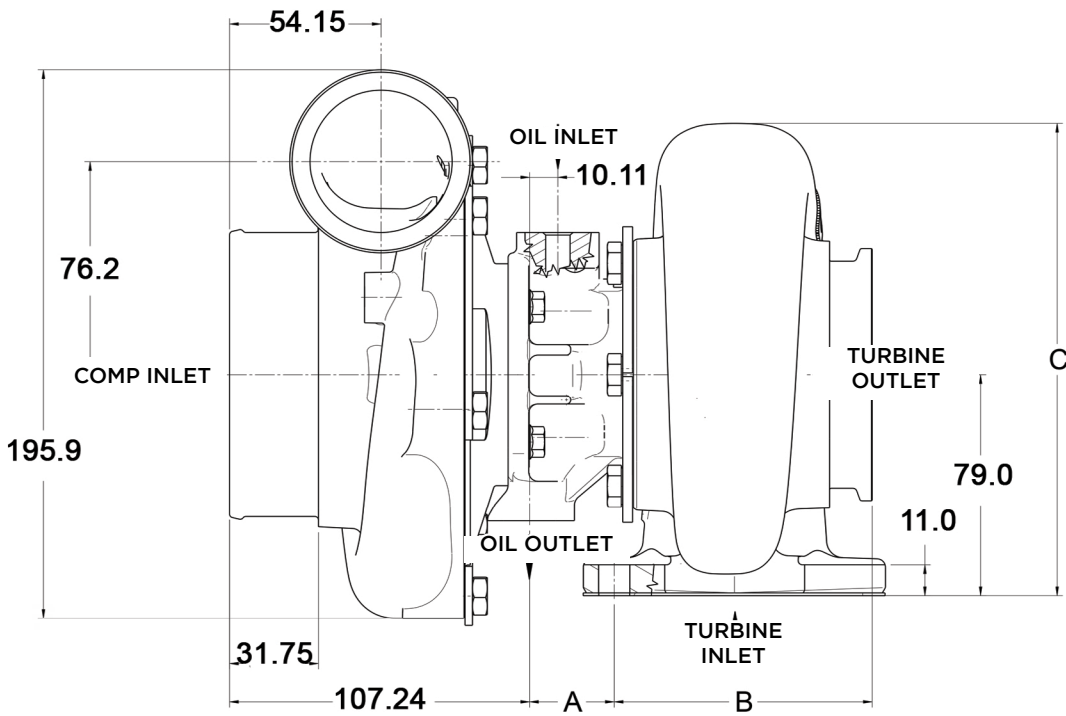

SIZE	TURBINE			
	-	T3 OP	T4 OP	T4 DIV
GBC-35/37	A/R	0.82	0.82	0.95
	A	30.29	27.84	27.84
	B	92.21	93.90	93.90
	C	168.8	179.1	181.2

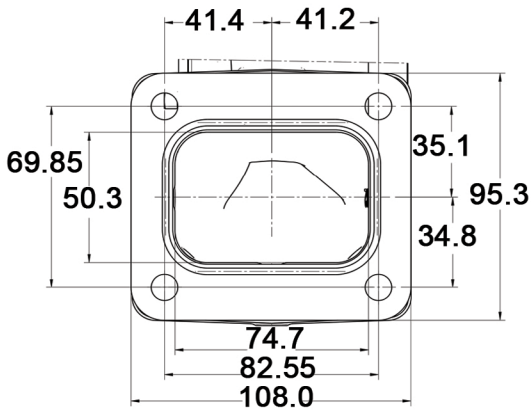
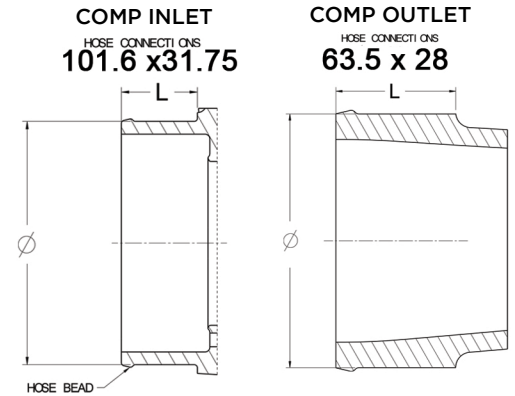

TURBINE INLET T4 OPEN

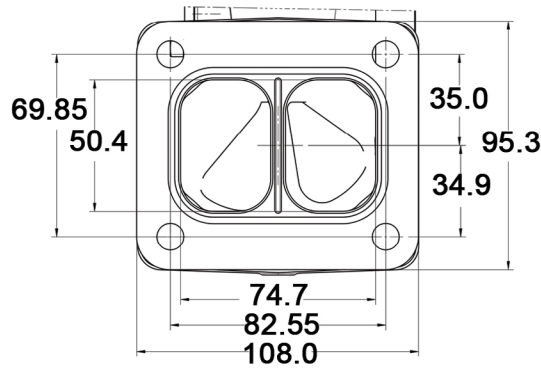

TURBINE INLET T4 DIVIDED

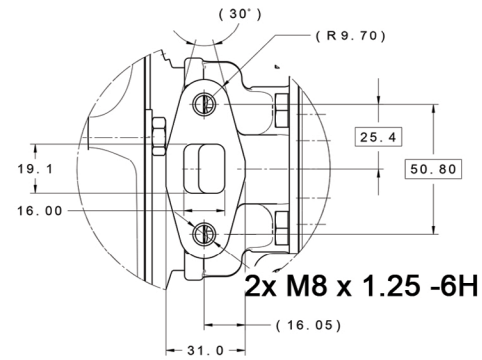

OIL OUTLET

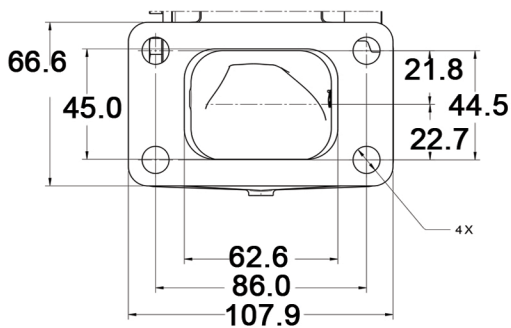

TURBINE INLET T3 OPEN

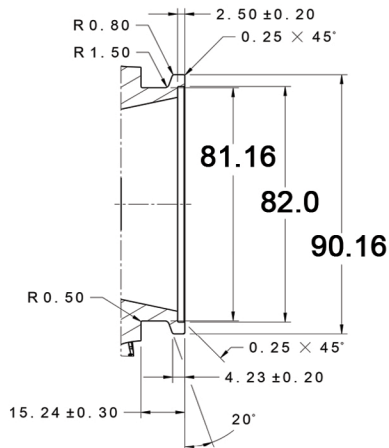

TURBINE OUTLET

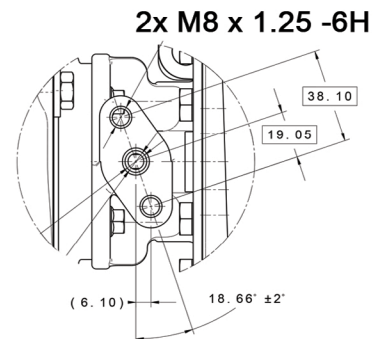

OIL INLET